

INOX | Saladette

SALADETTE ▶ GN1/1 ▶ OPEN TOP

CRQ 93A



		GAS R290		4 CLIMATIC CLASS	

DETAILS

Main switch and digital thermostat fitted as standard	Curved edge for easy cleaning	Engine room lock fitted as standard
Anti-condensation thermal-braker on door frame	Inner embossed door design for a better sealing	Sliding engine easy to pull out for manageable after sales servicing
Curved tempered glass with middle shelf	Inner assistance fan	Door design

GENERAL FEATURES

- GN1/1 Refrigerated saladette (OPEN TOP)
- Stainless Steel exterior and interior
- Static Cooling
- Automatic compressor cycle defrost
- Foaming Agent Cyclopentane (45mm per side)
- Digital Thermostat
- Sliding engine room for a manageable after sales servicing
- Plastic thermal-braker as chamber body frame
- Easy removable condenser filter
- Separated plastic water tray
- Front panel tilted holes for better air circulation
- Adjustable shelves GN1/1: 3 pcs
- Self closing door (New inner embossed design for a better sealing)
- Removable Gasket
- Engine room lock fitted as standard
- N.2 Adjustable feet in the front + N.4 fix rollers
- Holder spacer for GN pans (included)
- Energy efficiency class: -

TECHNICAL SPECIFICATIONS

Capacity	364L
Temperature	+0° ~ +8°C
Consumption	4.34 kWh/24h
Rated Power	233 W
Noise level	48 dB(A)
Net Weight	123 Kg
Gross Weight	156 Kg
External Dimensions (WxDxH mm)	1365x700x1295
Internal Dimensions (WxDxH mm)	1275x586x502
Packaging dimensions (WxDxH mm)	1420x750x1110
Loading quantities 20'/40'/40'HQ	12/24/48

PRODUCT DIMENSIONS

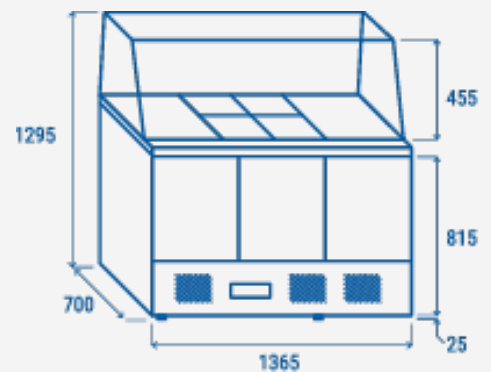

CERTIFICATION

CE RoHS

